



Comisión Naval de Regatas



Federación Gallega de Vela



Clase Snipe Galicia

50th "LAS ANCLAS" TROPHY



SNIPE CLASS

April 22-23, 2017

SAILING INSTRUCTIONS

1. Organization:

- 1.1 50th "LAS ANCLAS" TROPHY – 300th ANNIVERSARY REAL COMPAÑIA DE GUARDIAMARINAS, for sailboats of the SNIPE Class International, will be held in Ría de Pontevedra Bay, on april 22-23, 2017, organized by the Comisión Naval de Regatas of the Escuela Naval Militar, according to the Galician sailing calendar of the Snipe Secretary and the National Circuit of this Class.

2. Rules:

2.1.

- a) The "rules" as defined in the Racing Rules (RRS) of World Sailing 2017-2020.
- b) The Rules for Conducting National and International Championship of the SCIRA
- c) Appendix P (RRS) will be applied when the Jury decide.
- d) Rule 35 of the RRS shall be amended to score "DNF" without hearing those boats not complete the course within 15 minutes to the arrival of the first boat.
- e) Rules 62.2 and 66 of the RRS are amended to shorten the time to request a redress or reopening of hearing the last day of racing
- f) Rule 33 (RRS) is amended to limit course changes
- g) Rule 60.1(a) (RRS) is amended to limit the causes for protest a boat by specifics of sailing instructions and the notice of race
- h) Rule 63.7 /RRS) is amended for, if there is any conflict between the Sailing Instructions and the Notice of Race, the sailing Instructions will prevail.
- i) Part 4 preamble (RRS) is amended so that mandatory use of personal flotation device at all times while afloat
- j) The Notice of Race and the Sailing Instructions, which can modify the preceding Rules.

- 2.2. Measurement Control: The boats will be available for the Race Committee for inspection at any time

- 2.3. Official language: It will be the Spanish and prevail over others in an interpretation of these instructions.

3. Registration and eligibility:

- 3.1. Open to eligible skippers whose boats have been registered in accordance with the notice of race.
- 3.2. Participants shall be with the sail number contained in the measurement certificate, except written authorization of the Race Committee.
- 3.3. Same crew sailing in all races, except for justified reasons and with written permission of the Race Committee. Such authorization may be retroactive if the race Committee deems it appropriate.
- 3.4. Once a crew member has been excused, he will not participate in the rest of the races.

4. Changes to Sailing Instructions and notices to competitors :

- 4.1. All notices to competitors will be posted on the official notice board (TOA) located in the Race Office at Comisión Naval de Regatas hall.
- 4.2. Notices of the Race Committee or changes to the sailing instructions will be published (with corresponding signal) no more than 1 hour before the start of the Race Committee boat, except that any change to the schedule of races will be posted by 20:00 hours on the day before it will take effect.

5. Signals made ashore :

- 5.1. Signals made ashore will be displayed on signal mast at pontoon dock "GM CHEREGUINI" on the Esplanade of the military Naval school.
- 5.2. Flag "D" with a sound signal means: 'the warning signal will be made not less than 30 minutes after flag "D" is displayed.' Boats shall not leave their berthing places until this signal is made (except if they have the express permission of the Organization Committee and the regatta to do so).

6. Schedule of races and Race Format:

- 6.1. Programme:

DATE	HOUR	ACTION
SATURDAY <u>22th April</u>	10:30 hours	– Open Office Race
	12:00 hours	- Registration of competitors - Sailing Instructions available – Pic nics to the competitors
	14:00 hours	– Warning Signal Race 1 of day (provided 3 races)
	19:30 hours	– Dinner Seafood
SUNDAY <u>23th Abril</u>	11:30 hours	– Warning Signal Race 1 of day (provided 3 races) Pic nics to the competitors. (no warning signal will be made after 15.30 h.)
	17:00 hours	– Price Giving and Cóctel at Casino Alumnos of the ENM

- 6.2. 6 races are scheduled for each event. 1 race is required for the event be valid.
- 6.3. The last possible warning signal on Sunday 23th april is 15:30 h
- 6.4. Only 3 (three) races per day, except that the race Committee deems otherwise.
- 6.5. Only one fleet system race.

7. Racing Area:

- 7.1. The race course will be located in the Ria of Pontevedra, to the West of the island of Tambo
- 7.2. The situation of the race course can be modified:
 - a) posting on the official notice board, or,
 - b) in the water by a boat from the Race Committee that takes the flag "L" of the CIS which means: "the situation of the race course is changed. Follow me to new location".

8. Official boats identification:

- 8.1. The Race Committee boats will be identified with a **yellow flag**

9. The Courses:

- 9.1 No later than the preparatory signal, the Race Committee signal boat will display the approximate compass bearing of the first leg and the course signal (code flag "W", "T", "O")
- 9.2 Course "triangle with windward/leeward" (recommended 15 to 18 knots wind) indicated by the flag "Oscar" CIS and consist of Start-1-2-3-1-3-Finish:

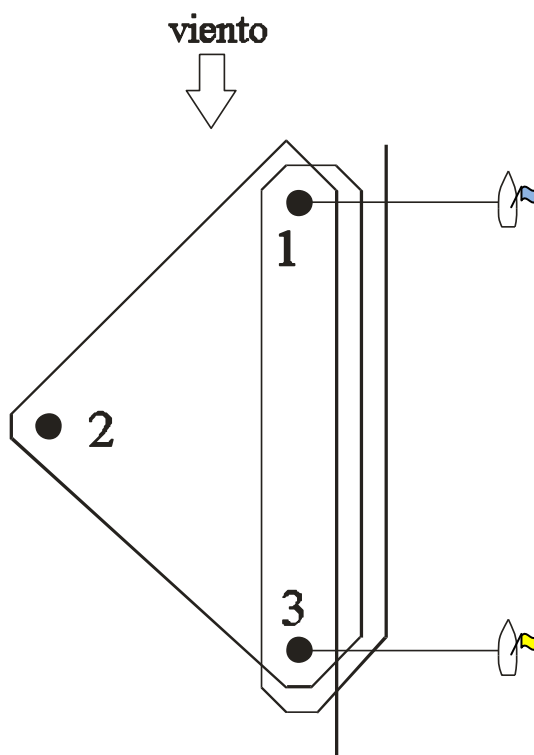

- 9.3 Course "double triangle ' (recommended 16 to 23 knots wind) indicated by the flag "Tango" of the CIS and will consist of Start-1-2-3-1-2-3-Finish."

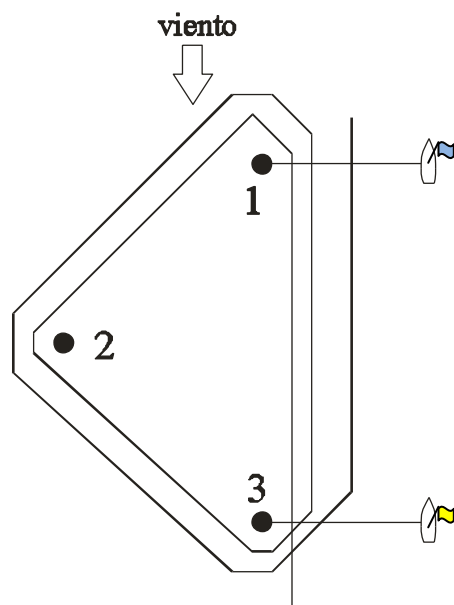

- 9.4 Course "Windward-Leeward" (recommended 6 to 18 knots wind) will be indicated by the "Whiskey" of the CIS flag and will consist in Start-1-2S/2P(Gate)-1-2S/2P(Gate)-Finish.

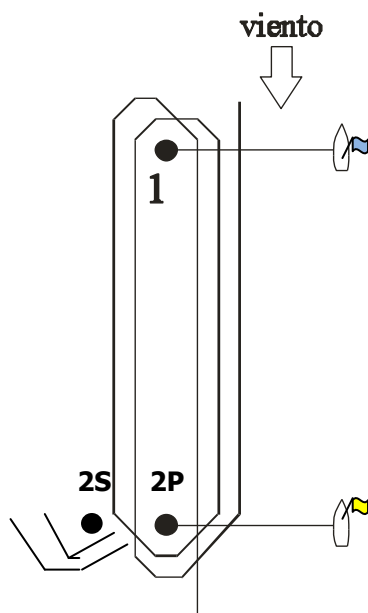

- 9.5 Starting will never be above 23 knots winds. If the wind speed rises and stays above 23 knots during the race more than 3 minutes at a time, the Committee may shorten the course or suspend the course. Starting will not be with winds less than 6 knots.
- 9.6 The Marks (except a Gate 2S/2P) will be attached to port.
- 9.7 The Races will be managed to last 40-45 minutes for the first boat to finish. A different time (shorter or longer) used to complete the race will not be ground for requesting redress.

- 9.8 Sustained wind variation of 20 degrees or more from the posted bearing during the first leg of a race shall result in the race to be abandoned and re-sailed, or abandoned.
- 9.9 A sustained wind variation of 40 degrees or more of the posted bearing during the first lap shall result in the race being abandoned and re-sailed, or abandoned.

10 Marks:

- 10.1 The original marks of the course will be inflatable, cylindrical yellow color.
- 10.2 The new Marks located in accordance with the rules of change of course will be inflatable, cylindrical orange color
- 10.3 To change the course after start, the race Committee anchored a new mark of Orange color and will lift the original yellow mark as soon as possible. In order to maintain the original configuration of the course reset can any mark that rounding after passing the new mark of orange color.
- 10.4 In a new change of course, to replace the mark Orange color, will be replaced by an original yellow color mark.
- 10.5 In case the marks are not anchored in the right place may not be cause for protest

11 The Start:

- 11.1 The starts will be using the following system, which modifies Rule 26 of the RRS:

SIGNAL	VISUAL SIGNAL	Mimutes to start
Warning	Snipe Flag up	5
	1 sound	
Preparatory	"PAPA", "INDIA" or "UNIFORM" flag up.	4
	1 sound	
Last minute	"PAPA", "INDIA" or "UNIFORM" flag, down.	1
	1 long sound	
Start	Snipe Flag, down	0
	1 sound	

- 11.2 The starting line will be between Mark 3 or 2P depending the course and the Race Committee boat with yellow flag
- 11.3 A boat starting later than 4 (four) minutes after her starting signal will be scored Did Not Start without a hearing
- 11.4 In adverse weather conditions, the race Committee boat will can maintain its position with engine.

12 CHANGE OF THE NEXT LEG OF THE COURSE AFTER START:

- 12.1 Para Changes to the next leg of the course shall be made using RRS 33. To change the next leg of the course, the race committee will lay a new mark (or move the finishing line) and remove the original mark as soon as practicable. When in a subsequent change a new mark is replaced, it will be replaced by an original mark.
- 12.2 Except at a gate, boats shall pass between the race committee boat signalling the change of the next leg and the nearby mark, leaving the mark to port and the race committee boat to starboard. This changes RRS 28.1

- 12.3 If the Race Committee decides to modify the position of the Leeward marks, will be repositioned the original marks.
If the Leeward (GATE) mark is a single mark, this will be left to port.

13 The Finish:

- 13.1 The finish line will be established between a blue flag on the boat of the race Committee, at the end of the starboard and the mark 1 or replace in the race of a change course at the port end.
- 13.2 Numeral 2 up on boat of the race Committee at the finishing line indicates that another race will be held then.
- 13.3 In adverse weather conditions, the race Committee boat will can maintain its position with engine.

14 Time limit:

Time limit to complete the first ship the course will be 70 minutes. Boats that finish later than 15 minutes after the arrival of the first boat, will be classified as DNF.

15 Protest and request for redress:

- 15.1 A boat that finishes and intends to protest, must inform the race Committee boat at the finishing line and also informing him of the sail number of the boat against the protest. A boat that retires or fails and intends to protest, must communicate the race Office immediately after his arrival to harbour, indicating the sail number of the boat against to protest
- 15.2 Protest forms are available at the Race Office. Protests and requests for redress or reopening shall be delivered there within the protest time limit.
- 15.3 The protest time limit is 60 minutes after the last boat has finished the last race of the day. This hour to show at TOA
- 15.4 Notices will be posted no later than 30 minutes after the protest time limit to inform competitors of hearings in which they are parties or named as witnesses
- 15.5 Notices of protests by the Race Committee or Jury will be posted in the official notice board to inform competitors according to rule 61.1(b).
- 15.6 Breaches of instructions 5.4, 17, 18, 19 and 20, will not be grounds for a protest by a boat. This changes rule 60.1(a). Penalties for these breaches may be less than disqualification if the protest committee so decides.
- 15.7 Time limit to request for redress by other acts follow at sea, ends 30 minutes after show classifications of the day, if this takes place before 20:00 o'clock, or 09:00 of the next day otherwise. This modifies rule 62.2 RRS.
- 15.8 On the last scheduled day of racing a request for reopening a hearing shall be delivered (the following changes rule 66), no later than 15 minutes after the requesting party was informed of the decision on that day.

16 Scoring:

- 16.1 Low Point System of Appendix A RRS will be used
- 16.2 when from 4 or more races have been completed, a boat's regatta score will be the total of her race scores excluding her worst score (modifies the Notice Race)
- 16.3 the ties will be resolved in accordance with A8 rule of Appendix A RRS

17 Support boats:

- 17.1 Team leaders, coaches and other support personnel shall stay outside areas where boats are racing from the time of the preparatory signal for the first class to start

until all boats have finished or retired or the race committee signals a postponement, general recall or abandonment.

The infraction of this instruction may result in the restriction of access to the race course during the event by the Jury or the Race Committee

18 Replacement of crew or equipment

- 18.1 Substitution of competitors will not be allowed without prior written approval of the race committee
- 18.2 Substitution of damaged or lost equipment will not be allowed unless authorized by the race committee
- 18.3 Requests for substitution shall be made to the committee at the first reasonable opportunity

19 Safety Regulations

- 19.1 When the Race Committee boat shows a flag with the emblem of the Red Cross on a white background, all coaches and support boats shall cooperate with the organizing committee in rescue boats that require it
- 19.2 All boats must return to their areas of grounding provided by the organization. Each boat is forced to land arriving at a point other than the assigned area and is prevented from returning to the parking area of the regatta on their own, immediately communicate this circumstance calling the focal point of the race Phone Race Committee : 00 34 608 823 036 (or calling on channel 69 VHF)
- 19.3 All competitors carefully observe this instruction of the race. Otherwise you will be required to pay the costs of search and rescue operations
- 19.4 Boats that are retired after finish (RET), to leave the course any time before end (DNF), must submit a form before the end of the period protest. Boats that do not have approached to the start line or to not leave the club for the day (DNC) races, shall notify it at the race office prior to the first race following warning signal.

20 Communications:

Except in an emergency, a boat shall neither make radio transmissions while racing nor receive radio communications not available to all boats. This restriction also applies to mobile telephones.

21 Prizes:

- 21.1 Minimum for the first three classified absolutes, owner and crew

Additional Information:

TIDES FOR THIS RACE AREA (Local time)

Marín – saturday 22th april		
	Hour	Height
High tide	01:24	2.9
Low tide	07:46	1.1
High tide	14:02	2.9
Low tide	20:07	1.1

Marín – sunday 23th april		
	Hour	Height
High tide	02:17	3.1
Low tide	08:33	0.9
High tide	14:48	3.2
Low tide	20:52	0.9

SUNSET TIME (Local Time) : Saturday 22th- April 2017 = 21:23 h.

MARÍN, April - 2017
EL COMITÉ DE REGATAS Y COMITÉ ORGANIZADOR